

Digital Hourmeters

ISO 9001
Certified

Performance and Value for Your Specialty Vehicle Application



Part #:
180-1911 (std)

These weather resistant panel mounted, DC input meters from TST offer value and performance. Built specifically for a wide range of specialty vehicle applications, these meters offer a compact and convenient mounting configuration.

Features:

- ❖ Displays up to 9,999 hours
- ❖ Automatically rolls over and continues to count
- ❖ Temperature range: -40 to 160 degrees F
- ❖ Quartz accuracy +/- .02% over operative voltage and temperature range
- ❖ Less than 1 mA current draw
- ❖ Voltage range: 8 VDC-32 VDC
- ❖ 100% epoxy encapsulated
- ❖ LCD height is .20"
- ❖ Connections are .250 male blade, faston type
- ❖ Display remains active when power is removed
- ❖ Display battery guaranteed for 15 years of service
- ❖ Only 1.25" total depth behind panel
- ❖ Special output for up to three resettable schedules (180-1912 only)
- ❖ Flashing alert indicator available to identify pre-set levels (180-1912 only)

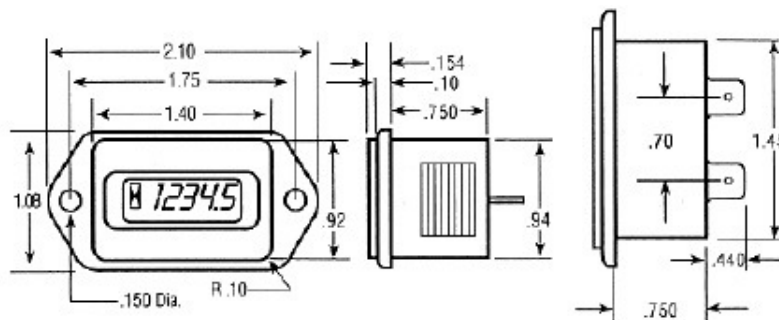

**Made in the
USA**

Contact your TST Representative for price and availability.



TST/Riverside Mfg., LLC
14510 Lima Road
Ft. Wayne, IN 46818
www.tst-corp.com

800-428-4449 Toll Free in USA
260-637-4470 Main
260-637-4472 FAX

www.riversidemfg.com



A Division of
RIVERSIDEMFG, LLC