

# Eagle Eye™ Obstacle Detection System

- Monitors side and rear “blind areas” or “no zones” for vehicles or objects
- Alerts driver to potential contact beginning at 8 to 10 feet away from his or her vehicle
- Improves overall driver hazard awareness

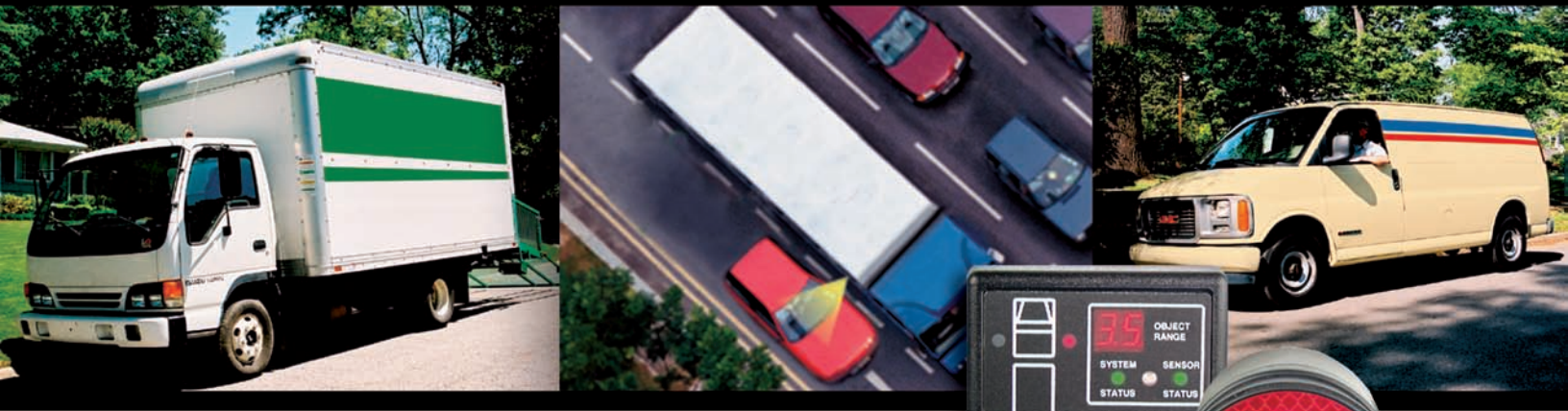

## Features & Benefits

### Driver Friendly

- Alerts driver only when an object is detected – no other attention required
- Assists during backing or lane change maneuvers in tight spaces or heavy traffic
- Enhances crash avoidance driving skills

### Affordable

- Lowers overall operating costs and boosts productivity
- Payback frequently occurs in less than 1 year
- Expandable – start with rear or side coverage only, add other zones later

### Versatile

- Up to 7 detection zones can be assigned on a vehicle
- Targets “blind areas” or “no zones” on sides or rear of vehicle
- Multiple system configurations to meet wide ranging needs
- In-dash or on-dash display mounts available

### Rugged and Reliable

- Weather resistant, heated sensors work in fog, rain, and snow
- Uses sealed connectors and damage resistant wiring
- Protective sensor hoods available for high impact environments

### Easy to Use

- Both automatic alerts
- Audio tone – single and double beeps at 10 and 5 feet from object when turn signal is active or transmission is in reverse
- Visual display – LEDs show position and distance from object
- Self checking system diagnostics

### Designed for Commercial Vehicles

- Tractor Trailers
- Straight Trucks
- Vans / Pickups
- Loaders

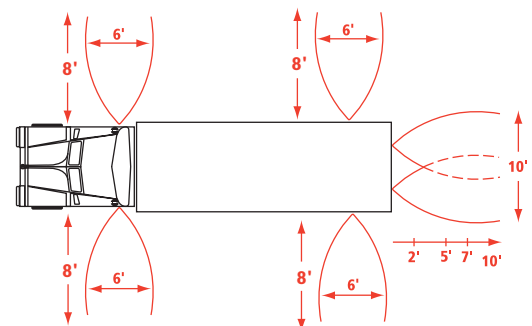

Transportation Safety Technologies, Inc.  
2400 Roosevelt Avenue, Indianapolis, IN 46218  
Phone: 800.428.4449 Fax: 317.263.0979  
www.tst-eagleeye.com

**Eagle Eye™**  
Obstacle Detection System

For More Information Call 1-800-428-4449 | Mon. – Fri. 8:00 am – 5:00 p.m. EST