

Commander™ 357

ISO 9001
Certified

High Current Disconnect Switch

TST's Commander™ 357 is a heavy duty 12 volt DC disconnect switch that is rated for 300 amp continuous duty and 350 amp peak electrical loads. Used in ambulances and other specialty vehicles, the Commander™ 357 is ideal for many vehicle 12 VDC applications with high current loads. Its microprocessor-based technology enables efficient and effective switching in a compact, easy-to-install device.



Designed for longer life, the Commander™357 features reduced internal contact arcing- a primary cause of wear and malfunction in electromechanical solenoid devices. Its built-in, selectable ignition interlock protects the vehicle's alternator by preventing inadvertent disconnecting of loads while the engine is running. Also, by combining the ignition interlock with the Commander™ 357's selectable 5-minute timed shutdown mode, it protects the vehicle batteries against accidental excessive discharge from leaving lights or other systems on after the vehicle is parked.

The Commander™ 357 can be configured for positive or negative enabling, offering flexibility in installation. The Commander™ 357 provides a combination of durability, features and flexibility that is hard to beat. To learn more about the Commander™ 357 in your application, please contact your local TST representative.

FEATURES and SPECIFICATIONS

- ❖ Easy to install and configure
- ❖ Compact, rugged construction
- ❖ Positive and negative enable
- ❖ Selectable shutdown timer and ignition interlock
- ❖ Diagnostic LED's
- ❖ **Size:** 6" long x 3.25" wide x 4" deep
- ❖ **Operating Input Voltage:** 9 to 16 VDC
- ❖ **Off State Current Draw:** 20mA
- ❖ **Operating Temperature Range:** -40 degrees F (-40C) to +180 degrees F (+82C)
- ❖ **Output Current Ratings:** 300 amps Peak Switching, 200 amps Continuous Dut

**Made in the
USA**

Transportation Safety Technologies
2400 Roosevelt Ave.
Indianapolis IN 46218

800-428-4449 Toll Free in USA
317-263-9160 Main
317-263-0977 FAX
www.tst-corp.com



DURABILITY

Commander™ 357

High Current Disconnect Switch

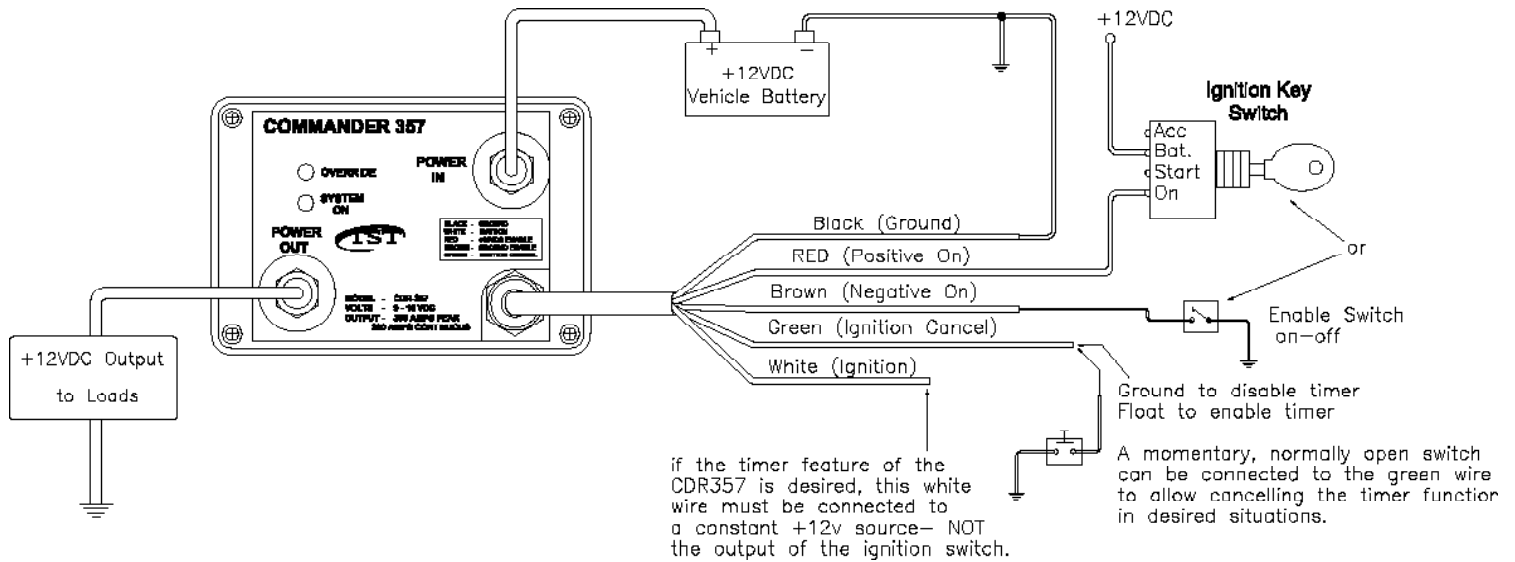

Use a small bladed screwdriver to carefully change to the delay desired. See the chart below for switch setting number/s and their corresponding times.

Position	Delay Minutes	
1	1	**After selecting desired time, replace the top cover and secure with its 4 screws, making sure lid gaskets in place.
2	3	
3	5	
4	7	
5	10	
6	12	
7	15	
8	20	
9	25	
10	30	